

12-1-2006

## Book Reviews

Follow this and additional works at: <https://digitalcommons.augustana.edu/swensonsag>



Part of the [Genealogy Commons](#), and the [Scandinavian Studies Commons](#)

---

### Recommended Citation

(2006) "Book Reviews," *Swedish American Genealogist*: Vol. 26 : No. 4 , Article 13.

Available at: <https://digitalcommons.augustana.edu/swensonsag/vol26/iss4/13>

This Article is brought to you for free and open access by the Swenson Swedish Immigration Research Center at Augustana Digital Commons. It has been accepted for inclusion in *Swedish American Genealogist* by an authorized editor of Augustana Digital Commons. For more information, please contact [digitalcommons@augustana.edu](mailto:digitalcommons@augustana.edu).

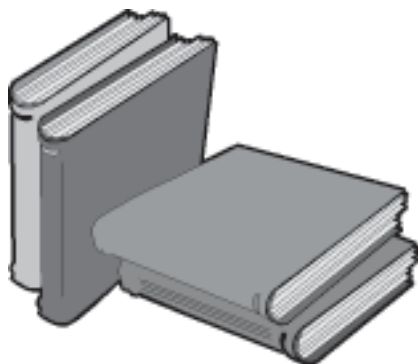

# Book Reviews

Here you will find information about interesting books on the immigration experience, genealogical manuals, books on Swedish customs, and much more. We welcome contacts with SAG readers, suggestions on books to review perhaps. If you want to review a book yourself, please contact the Book Review Editor, Dennis L. Johnson, at <1\_viking@verizon.net> or Dennis Johnson, 174 Stauffer Road, Bucktown Crossing, Pottstown, PA 19465, so he knows what you are working on.

## New Sweden Churches

***Colonial Records of the Swedish Churches, Volume I and Volume II***, by Peter Stebbins Craig, Editor, and Kim-Eric Williams, Assistant Editor, Swedish Colonial Society, 2006, hardcover, 218 pp. (Vol. I) and 221 pages (Vol. II), Swedish Colonial Society, Philadelphia, \$25.00 each volume (\$20.00 for members), plus shipping.

Most Swedish Americans are quite familiar with the general picture of the populating of the American nation by immigrants from Sweden in the 19th century. Often referred to as “The Swarming of the Swedes,” this migration occurred from the 1850’s until the early decades of the 20<sup>th</sup> century. Our own family histories usually include recollections of the stories of our grandparents or great-grandparents and their great adventure in coming from Sweden to the United States.

Less well known among most Swedish Americans is the story of the New Sweden Colony on the Delaware River, which took place more than 200 years before the beginning of the great migration. This was a time when many European nations were looking to establish colonies in North America, the time of Jamestown, Virginia, of Plymouth in Massachusetts, New Amsterdam on the Hudson River, and in other locations.

By 1637, over 150 years before the United States achieved independence, a group of Swedish, Dutch,

and German investors formed the New Sweden Company to trade for tobacco and furs in North America. Two sailing ships, the *Kalmar Nyckel* and the *Fogel Grip*, set sail for North America, reaching Delaware Bay in March of 1638. A fort was built in what is now Wilmington, Delaware, named Fort Christina to honor Sweden’s young queen, then only twelve years old. During the next 17 years, eleven more ships arrived in New Sweden, bringing the little Colony about 600 more Swedes and Finns. Over the next twenty years the Colony established farms and small settlements along both shores of the Delaware River, on lands which were to later become Pennsylvania, Delaware, New Jersey, and Maryland.

Swedish sovereignty over the Colony ended by 1655, when Governor Stuyvesant of New Amsterdam established his rule over New Sweden. They were allowed to govern themselves, however, and remained independent until 1681, when William Penn received his charter for Pennsylvania and Delaware and established English rule.

(For more information on the history of New Sweden, see the website of the Swedish Colonial Society at [www.colonialswedes.org](http://www.colonialswedes.org) )

The descendants of these early Swedes who remained in New Sweden in subsequent years were mainly interested in farming. They scattered throughout the Delaware Valley to claim lands and raise their families. Meanwhile, Philadelphia, Wilmington, and other towns in the area grew and became centers of trade, government, and industry. Many of these Swedes intermarried with English,

German, Dutch, and other settlers or townsmen, and became part of the social fabric of early Pennsylvania, Delaware, New Jersey, and Maryland. In later years, their many descendants with family origins in this small New Sweden Colony were to spread all over the United States.

The Swedish Colonial Society of Philadelphia has just published in two volumes the records of the Swedish Churches in Pennsylvania, as part of its ongoing research and publication of books about New Sweden. These publications began with the well-known work of Amandus Johnson, *The Swedish Settlements on the Delaware*, in two volumes, printed in 1911. The Swedish Colonial Society was founded in 1908 by descendants of the Colonial Swedes, under the leadership of Dr. Amandus Johnson, “to collect, preserve, and publish records, documents, and other materials” relating to the history of the Swedes in Colonial America. These two new volumes are the latest in a series of over ten books and many other publications intended to fulfill this objective.

### **Volume I The Log Churches at Tincum Island and Wicaco, 1646-1696**

Volume I was intended to collect in one place all available documentary history of the original log churches built in New Sweden by the Swedish colonists. The first log church was built in 1646 on Tincum Island near the west side of the Delaware River, on land now washed away but near land part of which now is the site of

# Book Reviews

the Philadelphia International Airport. This log church served the settlers for 42 years under three Swedish pastors, ending with the death of the third, Lars Carlsson Lock, in 1688.

The second church, also of logs, was built in 1677, and was located in Wicaco close to the future site of downtown Philadelphia and also facing the Delaware River. After much debate about location, both of these log churches were replaced in 1700 by a new brick church on the site of the Wicaco log church, called *Gloria Dei (Old Swedes') Church*. The log churches disappeared, but Gloria Dei exists today as the oldest surviving church building in Philadelphia. Three more churches were founded later in the 18<sup>th</sup> Century by members of Gloria Dei as they dispersed further into outlying areas: St. Gabriel's in Douglassville, St. James in West Philadelphia, and Christ Church in Merion, Montgomery County. Further south, the Swedes built a church near Fort Christina, in what is now Wilmington.

The editors of Volume I have laboriously assembled as many of the records as possible of the two original log churches which preceded Gloria Dei. Many of the parish records of these churches did not survive, but the authors were able to find many references relating to the time of these churches in old correspondence, journals, court records, land patents, deeds, minutes, and other documents. These were laboriously collected, translated where necessary, and incorporated into this volume. The documents are arranged in chronological order, well referenced, and with a minimum of editorial comment used mainly for clarifications of persons and place names. The documents speak for themselves, and are a rich source for those seeking records of the involvement of their own ancestors in

the New Sweden Colony. To the more general reader, the documents taken as a whole provide a fascinating picture of life at that time in the New Sweden Colony.

## Volume II, The Rudman Years, 1697-1702

During the log church years, Swedish pastors served these early churches built by the first settlers, most of whom retained the Lutheran traditions they had brought with them from Sweden. The few pastors from Sweden who had served these churches, and most of the original settlers, had passed on by the 1690's. The second and third generation had by then begun to drift away from the churches and Lutheran practices. Despite written requests by church elders, new pastors had not been sent from Sweden due mainly to the home country's preoccupation with its involvement in the wars against the Danes during the 1670s.

Letters sent by Church elders in 1696 finally bore fruit when Carl XI was King of Sweden. Two pastors and a shipment of Bibles and psalmbooks were sent by Archbishop Swebilius to the people in New Sweden and Sweden's "American Mission." Anders Rudman arrived in 1697 and he immediately set about to rejuvenate the congregation. He led the efforts to build the new brick church, completed in the year 1700. The other pastor, Eric Björk, provided

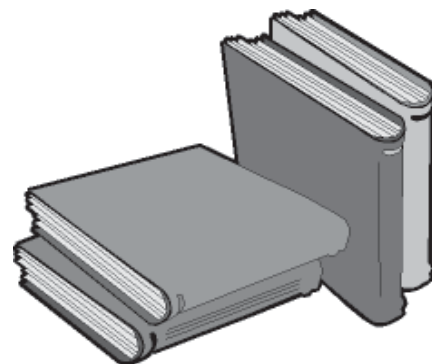

inspiration to the lower congregation at Crane Hook on the Christina River and caused a new brick church to be built there, now Old Swedes' in Wilmington, Delaware.

Volume II is a collection of documents from the years 1697-1702, focusing on this period and the work of Pastor Rudman in building up the Gloria Dei Church and congregation. About 50 documents in all are included, translated into English and with numerous editorial clarifications and comments. Rudman's narrative of the history of the church in New Sweden is especially informative. Other documents include various letters among the principal persons involved during these years, church records and accounts, minutes, construction accounts, and other papers. Maps and illustrations accompany these documents, and even a list of the assignments of church pews at Gloria Dei is included.

The editors have taken special care to correctly identify place names, many of which have had their spelling or names changed over the years. The names of colonists are also clarified, since most families abandoned the patronymic within a few generations after coming to America, and others in succeeding generations changed the spelling of their names in different branches of the same families.

Volumes I and II, intended to be the first in a series, contribute greatly to the reference works about the colonial period of New Sweden and these collections ease the burden of scholarship among scattered sources in several languages, for all

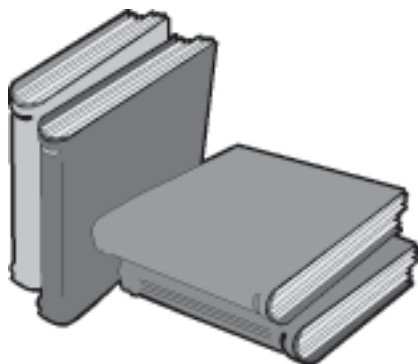

# Book Reviews

those interested in this period. Descendants and other readers will find this to be a rewarding source of information about the general character of life and times for colonial settlers in the Delaware Valley several generations before the American Revolution and at least a dozen generations before the present time.

*Dennis L. Johnson*

## A look at Sweden and America

***The Old Country and the New: Essays on Swedes and America***, by H. Arnold Barton, 293 pp., Ill., 2007, Southern Illinois University Press, Carbondale IL, Hardcover, Amazon.com, \$48.40 + shipping.

This newly published book by H. Arnold Barton joins a long list of books, essays, and other publications by this leading scholar of Swedish American studies. A collection of some seventeen essays and six editorials, the book was compiled from research conducted by the author between 1974 and 2004. Wide-ranging in focus, the articles taken as a whole provide a concise history of Swedish migration to the U.S. from the earliest settlers up to the present day. Eminently readable by scholar and lay reader alike, interesting and little known facts about the migration turn up in nearly every chapter. Many anecdotal stories about individual migrants are used to illustrate the overall sweep of this great mi-

gration experience.

The author is a great-grandson of Swedish migrants to the Midwest, to Illinois, Iowa, and Nebraska. The surname Barton was taken by his grandfather Ernest Swenson in the 1880s when Ernest became a physician. He took the name in admiration of Clara Barton, the heroic Angel of Mercy in the American Civil War and later founder of the American Red Cross.

H. Arnold Barton was trained as a historian and is now Professor Emeritus of History at Southern Illinois University, Carbondale, IL. In 2000, he received the Order of the Polar Star from King Carl XVI Gustav, and in 1988 he was named Swedish American of the Year by the Royal Swedish Ministry of Foreign Affairs and the Vasa Order of America.

In his first chapter, Barton reviews the works of many of his predecessors in writing about the history of Scandinavian immigrants to the New World. He includes a brief nod to the small group of Swedes and Finns involved in the New Sweden settlement in the Delaware Valley beginning in 1638. The next two chapters discuss the early individual Swedish visitors and migrants to America and, in 1846, Eric Jansson and his followers who founded the Bishop Hill settlement in Illinois. Succeeding essays address the reactions of Swedes in the homeland to the migration, the experiences of those who moved to Swedish America, the experiences of women, and the cultural conversion from Swede to Swedish American in the new land. Barton discusses the influence of immigrant letters, and the images of Sweden held by the new Americans.

An interesting sidelight is an article about William Widgery Thomas Jr., an American of Welsh background who became American Consul to Sweden at the time of our Civil War and later served for many

years. He was a devoted Sweden enthusiast who wrote admiringly about Sweden and her history. In his later years he divided his time between a home in Portland, ME, and a villa by the sea in Karlshamn. He left a legacy of Swedish American descendants who were bicultural and lived in both countries.

Final chapters deal with the more recent history of Swedish migration to the U.S., during and after World War II and in the post-war period. There is also a chapter about re-migration to Sweden, estimated to have totaled about 18 per cent over the entire period. Barton then reviews his research into his own family history in a chapter titled "A Historian as Genealogist." In a concluding chapter, Barton engages in some more relaxed reflections on Swedish America from several perspectives, with his insights into various interesting aspects of the immigration experience. He comments about the experiences and attitudes of second and third generation Swedish Americans, and their search for romantic images of the Sweden that never was.

This is a scholarly work, with abundant footnotes at the end of each chapter documenting all of Barton's sources and facts. Unlike many scholarly works, however, the book is most enjoyable and readable throughout and adds much to the knowledge of all those interested in the Swedish American experience.

*Dennis L. Johnson*

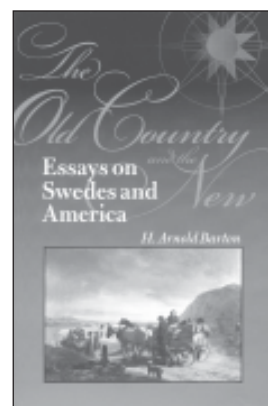



# Book Reviews

## A lucky man

***The Platinum King, Andrew Olsson's Story***, by Jan Olof Lindstrom and Karen L. Olson, 2004, Book Publisher's Network, Bothell, WA, 336 pp., Illus., Softcover, Amazon.com, \$17.95 plus shipping.

In 1903, a young man, just eighteen years old, packed his "America Trunk" (an old sea chest inherited from an old sailor friend) and left with others from his village to travel to America. He and many of his relatives lived in the little farming village of Krokvåg, in Jämtland, Sweden. He was following in the path of other neighbors and relatives who had already left to immigrate to America in the previous decades, inspired by the "America Fever" raging at the time in Sweden. Nearly half of the people in his village had left already, and still more were to follow.

Anders Olof Olsson was born in 1885, son of Olof Olsson and Karin Edlund. Karin died during his birth and he was raised by his mother's parents, Johannes Edlund and Justina Andersdotter. His father lived close by, and Anders was related to most of the other people in his small village. He had a sister two years older than he, Elin, and his father had remarried and raised seven more children. Anders Olof had done farm work, spent summers in a *fäbod* (shepherd's cottage) in the hills, and much time wandering the forests and rivers near his home. His grandfather died when he was twelve and a few years later he found it heart-breaking to tell his beloved *mormor* that he was going to America. Farming life was not for him. He traveled with his neighbor, Johan Petter Almgren and his family, who were planning to join relatives in Washington State, near Stanwood. They hoped to find a farm there.

Anders Olof had little desire to become a farmer. As a child he had listened to adventure stories from his old sailor friend who had returned to his village. Anders was determined to have a life of adventure, perhaps even search for gold. In Washington, he worked for a while as a farm hand but by 1906 was headed for Alaska to seek his fortune. With a friend he met in Seattle, he took a job with a mine operator named Strandberg at a mine outside of Fairbanks. Anders (now Andrew) loved the remote country and thrived on the hard work of mining, learning all he could as he worked. He would spend the season from April until October in Alaska, then return to Washington for the winter to work for relatives on their farms.

Andrew's plans to mine gold soon suffered a two-year setback, however. While in Seattle, a wagon had run over his leg, as a result of his trying to help hold a stranger's team when the horses bolted. His leg healed slowly and painfully, but by 1911 Andrew again headed for Alaska with his cousin, Daniel. He had done some research while recuperating and decided to try gold panning in Flat, Alaska, a remote place over three week's walk from Fairbanks. While working there, they developed ideas of using machines to speed the search for gold. Andrew's father had by then moved to Washington, and in the fall Andrew joined him to help him build a new house and develop his new farm there. By 1915, he again returned to Alaska with his brother-in-law Will and his half-brother Manne to explore claims he had leased near Flat. They wintered over in Alaska, and developed a method of melting the permafrost with steam to extend the mining season.

Andrew decided to return to Sweden in 1918 to visit his *mormor* on her 90<sup>th</sup> birthday, staying for some time visiting friends and relatives in

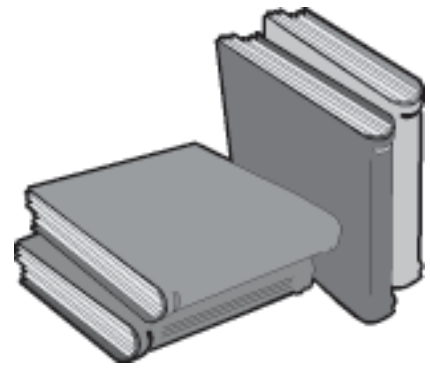

the area. He soon returned to Washington to resume his Alaska mining, and then returned again to Sweden in 1922 on the death of his *mormor*. He worked there a year, and then spent a year in Russia to study mining techniques in the Ural Mountains. Returning to Sweden, he proposed to his cousin Karin. She was willing to marry him but refused to leave her home village. Andrew returned to America saddened but alone; he was not willing to give up his dream for marriage.

By 1924, however, Andrew had met and married a woman with two sons who had emigrated from Sweden, Frida Strömberg. Andrew soon became very attached to her two young boys, Bertil and Alf. In 1925 Andrew with Frida returned to Alaska, leaving the boys in the care of relatives to get an education. Frida learned trekking in the wilderness, driving dog teams, and sharing in Andrew's mining work. In 1927, he established his own claim and mining company near the village of Flat, along with two Swedish partners. They continued mining for gold, adding larger and new equipment to save on labor. Frida cooked for the mining crew and helped with operations. Work continued at Flat and the scale of the operation increased year by year as other relatives and partners joined in the venture.

In 1934, Andrew and his partners decided to open operations at a new location at Goodnews Bay on the Bering Sea. Platinum had been discovered there in 1927 and a few miners were engaged in small hand operations panning for this valuable metal, not previously found in North America. Andrew and partners de-

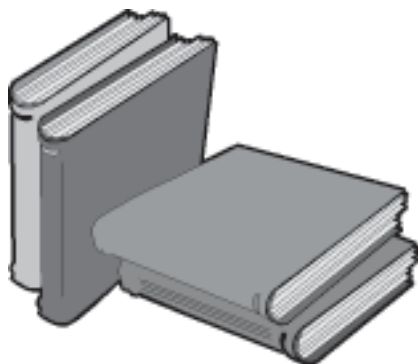

# Book Reviews

cided to lease claims in the area and open larger scale operations with large dredges and other equipment. Beginning on Squirrel Creek, the operations of the new Northland Development Company had extracted over 2,500 ounces of platinum at about \$113.00 an ounce. Through the 1930's, operations continued to expand and by the start of World War II in 1941, platinum had become a strategic material, with miners exempt from the draft and soldiers sent to protect mining operations.

One interesting sidelight to the Andrew Olson story took place in 1933 when, on July 20, an airplane engine was heard over Goodnews bay. The plane circled and made a crash landing on their short, rough airstrip, nose-diving into a ditch. The exhausted pilot turned out to be Wiley Post flying his "Winnie May" around the world solo. He had become lost searching for the city of Nome on a long flight from Khabarovsk, Siberia, to Alaska. While Wiley got some much-needed sleep, Andrew's miners repaired the *Winnie May* with repair parts flown in from Fairbanks. Soon Post was on his way to Fairbanks and then to New York, completing his record flight on July 22.

Andrew continued his pattern of many years, spending long summers in Alaska overseeing mining operations. He would return late in the fall to his farm near Snohomish, WA, and later to the home he and Frida purchased in Seattle, on Queen Anne Hill. Frida and the boys would often accompany Andrew to Alaska in the summer. Platinum is found in minute quantities in the ore, so enormous amounts of ore must be moved and

processed to extract the platinum. Operations expanded through the 1950's with a growing demand for platinum in industry. Even though Andrew became the largest miner of platinum in Alaska, it was said that the total amount his company mined over the years was only about one cubic meter, or a block about the size of a card table. (The price of platinum today is over \$1,200 per ounce).

Andrew's wife Frida became seriously ill in 1941 and, after surgery and tests, succumbed to inoperable cancer in March 1942. Andrew continued his mining work and left their house in Seattle, buying another farm in Silvana County, WA. By April 1945 he remarried, to Dee Dodge, a younger woman with one young son, Jack. To celebrate their marriage, Andrew and Dee undertook a motor trip on the newly completed Alcan Highway through Canada to Alaska, the first private automobile to do so. They then settled on the farm in Silvana and built a new home there. In 1952 Andrew brought his new family back to his home village in Sweden where he entertained relatives and others with films of his mining in Alaska. Andrew finally retired in 1970 at age 85, and died in March 1981 at age 96. He left a legacy of a large and extended family, many honors and awards from the mining industry, and generosity as a donor to many worthy causes including education of youth in his home village.

This fascinating book chronicles the amazing life of a young Swede who built success and fame in his adopted land through hard work, inventiveness, and integrity. The title of the book, *The Platinum King*, is fitting for the man who created the industry for the mining of platinum on a large scale in North America. Andrew Olson, although not as well known as others, joins the ranks of the many Swedes, born in poor circumstances, who achieved success

and fame in America yet never forgot their Swedish heritage of industry, honesty, and faith in God.

The book's co-author, Jan Lindstrom, also born in Krokvåg, Sweden, in 1934, has had a varied career to eventually become a technical draftsman and head of his own company. He has long been interested in genealogy and has traced many descendants from his parish to the United States. He has traveled to the U.S. to visit relatives and has put on genealogical exhibitions in both countries. These interests led him to undertake this biography of Andrew Olson in cooperation with Karen Olson of Seattle. She is married to Dennis Olson, a distant relative of Andrew Olson. She has researched her own genealogy and works as a writer and editor in Seattle.

This biography places its greatest emphasis on the family history of Andrew Olson, his immediate family, and his descendants including many who worked with him in his mining enterprises. The tone is that of a modest family history, giving credit but not aggrandizement to a person of Andrew's considerable accomplishments. It is made more readable by including many imagined conversations but the basic facts of his life ring true. There is less emphasis on the details of his business career, inventions, and his organizations and partnerships and his financial success. Numerous photographs and sketches are included to illustrate the people, homes, mining locations, and the times described in the biography.

This book is definitely recommended reading for all those interested in the accomplishments of successful Swedes in America, as well as those wishing a vivid picture of the times and places where Andrew lived, both in Sweden and in the U.S.

Dennis L. Johnson

New Sweden, ME 04762. (207) 896-3922. Richard@fbcns.com. Welcome! Aside from promotional materials, no stock photography is used on this site. All photographs are of New Sweden or the surrounding area. 1. The First Baptist Church. 1. of New Sweden, Maine. 1.Â Click on the above link to listen to sermons via YouTube. Link will open in a new tab. 1. Sermon Broadcasts. Welcome to Church FinderÂ® - the best way to find Christian churches in New Sweden ME. If you are looking for a church JOIN FOR FREE to find the right church for you. Churches in Aroostook County Maine and zip code 4762 are included with reviews of Baptist churches, Methodist churches, Catholic churches, Pentecostal and Assembly of God churches, Lutheran churches and other Protestant and Catholic Christian churches. Christian Churches in New Sweden Maine. Church Profile Â». Christianity in Sweden. Denominations. Church of Sweden.Â Christian Democratic Party. Swedish Association of Christian Social Democrats. Development agencies. Church of Sweden. Traditions. Saint Lucy's Day. Trinity Church (Swedesboro, New Jersey). Retrieved from "https://en.wikipedia.org/w/index.php?title=Category:Churches\_in\_New\_Sweden&oldid=942554125". Categories: New Sweden. Churches in the United States. History of Christianity in the United States. Navigation menu. The purpose of New Sweden Mission Church is to allow His Glory to be seen by worshipping the Lord Jesus corporately and individually, bringing people to Spiritual Maturity and reaching out to the lost world. New Sweden Mission Church.